



SOLUZIONE PER LA STIRATURA - LINEA FI  
IRONING SOLUTION - FI SERIES

SCHEDA COMMERCIALE  
COMMERCIAL SHEET

**MANGANI A RULLO FI 1000 - 1250 - 1500 Ø 25**  
**FLATWORK IRONERS FI 1000 - 1250 - 1500 Ø 25**



SCANSIONA PER ALTRE INFO  
SCAN FOR MORE INFO

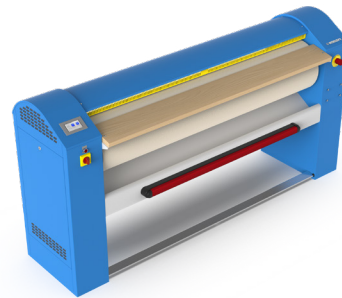
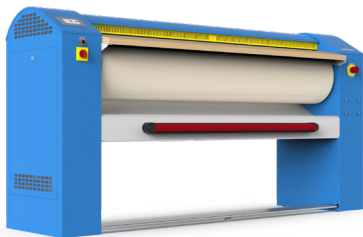
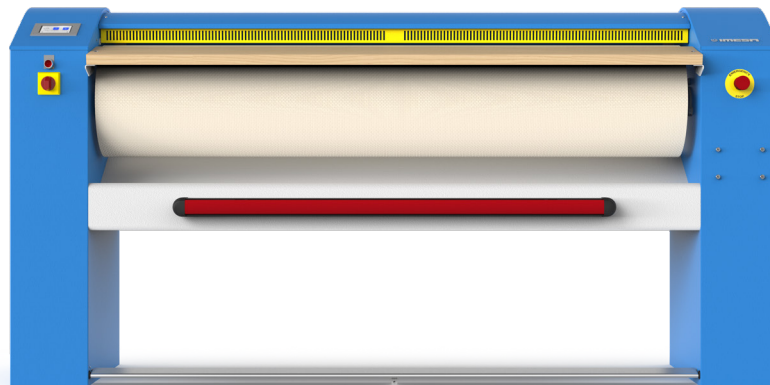

VALORI PRODOTTO / HIGHLIGHTS



IM 10 - Computer Touch screen  
IM10 - Computer Touch Screen



Infiniti programmi di stiro e parametri stiratura modificabili a ciclo avviato  
Infinite ironing solutions and adjustable ironing parameters during the cycle



Variazione automatica della velocità di stiro in funzione della temperatura con sistema Cool Down  
Automatic regulation of ironing speed depending on residual moisture. Cool down system included.



Azionamento lineare per controllo della pressione di stiro  
The linear activation function allows ironing pressure to be controlled and adapted to the type of treated fabric.



Barra di torsione per l'uniformità della pressione della conca su tutta la lunghezza del rullo  
Torsion bar guarantees uniform pressure of the chest throughout the entire length of the roller



Inverter di serie per il controllo elettronico della velocità di stiro e pedaliera per avvio e stop stiratura  
Electronic ironing speed control by inverter and ironing start and stop pedals



Posizione del tavolo di introduzione regolabile  
Adjustable introduction table



Telo di rivestimento in NOMEX di serie, resistente ad alte temperature  
Nomex chest paddle as standard



Barra anti panico sul fronte della macchina  
Anti-panic bar on the front of the machine



Conca di riscaldamento in acciaio cromato  
Chromed steel heating chest



CONTROLLO DELLA PRESSIONE  
-Tecnologia brevettata - TV2008A000116  
PRESSURE CONTROL  
- Patented technology - TV2008A000116

OPTIONAL / OPTIONS

- Aspirazione / With suction system



**DATI TECNICI\* / TECHNICAL DATA\***
**FI 1000 Ø25**
**FI 1250 Ø25**
**FI 1500 Ø25**

|   |                                |                                |                                |
|---|--------------------------------|--------------------------------|--------------------------------|
| - Lunghezza utile di stiro / Ironing width  | 1000 mm (39,4 inch.)           | 1250 mm (49,2 inch.)           | 1500 mm (59 inch.)             |
| - Diametro del rullo Ø / Roller diameter Ø  | 250 mm (9,8 inch.)             | 250 mm (9,8 inch.)             | 250 mm (9,8 inch.)             |
| - Produzione oraria** / Hourly production**   | 25 kg/h (55 lb/h)              | 30 kg/h (66 lb/h)              | 35 kg/h (77 lb/h)              |
| - Evaporazione** / Evaporation**  | 5 lt/h                         | 6 lt/h                         | 7 lt/h                         |
| - Velocità di rotazione / Rotation speed  | 1÷6 mt/min                     | 1÷6 mt/min                     | 1÷6 mt/min                     |
| - Pressione di stiro / Ironing pressure   | 214÷322 kg/m <sup>2</sup>      | 214÷322 kg/m <sup>2</sup>      | 214÷322 kg/m <sup>2</sup>      |
| - Scarico aria umida (pos. 1) Ø / Humid air (pos. 1) Ø  | (opt.) 73 mm (2,9 inch.)       | (opt.) 73 mm (2,9 inch.)       | (opt.) 73 mm (2,9 inch.)       |
| - Portata aria umida / Humid air flowrate   | (opt.) 200 m <sup>3</sup> /h   | (opt.) 200 m <sup>3</sup> /h   | (opt.) 200 m <sup>3</sup> /h   |
| - Intensità sonora area / Air sound intensity   | 55 db (A)                      | 55 db (A)                      | 55 db (A)                      |
| - Perdite al mantello / Heating leak  | 3 %                            | 3 %                            | 3 %                            |
| - Filetto piedini / Feet thread   | M10                            | M10                            | M10                            |
| - Dimensioni macchina : LxPxH / Machine Dimension : WxDxH (100 mm = 3,93 inch.)               | 1513x671x1087 mm               | 1763x671x1087 mm               | 2013x671x1087 mm               |
| - Peso netto / Net weight   | 159 Kg (350 lb)                | 174 Kg (383 lb)                | 198 Kg (436 lb)                |
| - Dimensioni imballo standard: LxPxH / Standard packing dimension WxDxH (100 mm = 3,93 inch.) | 1620x724x1203 mm               | 1870x724x1203 mm               | 2120x724x1203 mm               |
| - Peso lordo / Gross weight   | 176 Kg (388 lb)                | 192 Kg (423 lb)                | 218 Kg (480 lb)                |
| - Volume imballo / Packaging volume   | 1,2 mc (42,4 ft <sup>3</sup> ) | 1,4 mc (49,4 ft <sup>3</sup> ) | 1,6 mc (56,5 ft <sup>3</sup> ) |
| - Macchine imballate STD per container 20' / STD. packed machines in to 20' container         | 11 pz.                         | 9 pz.                          | 8 pz.                          |
| - Macchine imballate STD per container 40' / STD. packed machines in to 40' container         | 24 pz.                         | 19 pz.                         | 17 pz.                         |

**DATI MACCHINA RISCALDAMENTO ELETTRICO / ELECTRIC HEATING MACHINE DATA**

|   |               |               |                |
|---|---------------|---------------|----------------|
| - Riscaldamento elettrico / Electrical Heating                                      | 4,5 kW        | 5,4 kW        | 7,5 kW         |
| - Potenza totale (pos. 2) / Total Power (pos 2.)                                    | 4,9 kW        | 5,8 kW        | 8,1 kW         |
| - Assorbimento / Absorptions (3 ph 400V-440V (+N) / 3 ph 230V / 1 ph 230V 50/60 Hz) | 7 / 12 / 22 A | 9 / 16 / 27 A | 13 / 23 / 37 A |
| - Consumo orario ** / Hourly consumption**  | 4,0 kWh       | 4,7 kWh       | 6,2 kWh        |

\* I dati sono riferiti a macchine dotate di aspirazione / Data refer to aspiration fan machines.

\*\* 20% di umidità residua e utilizzo del rullo al 100% (ISO 9398) / 20% of residual humidity and use of 100% of roller length (ISO 9398)

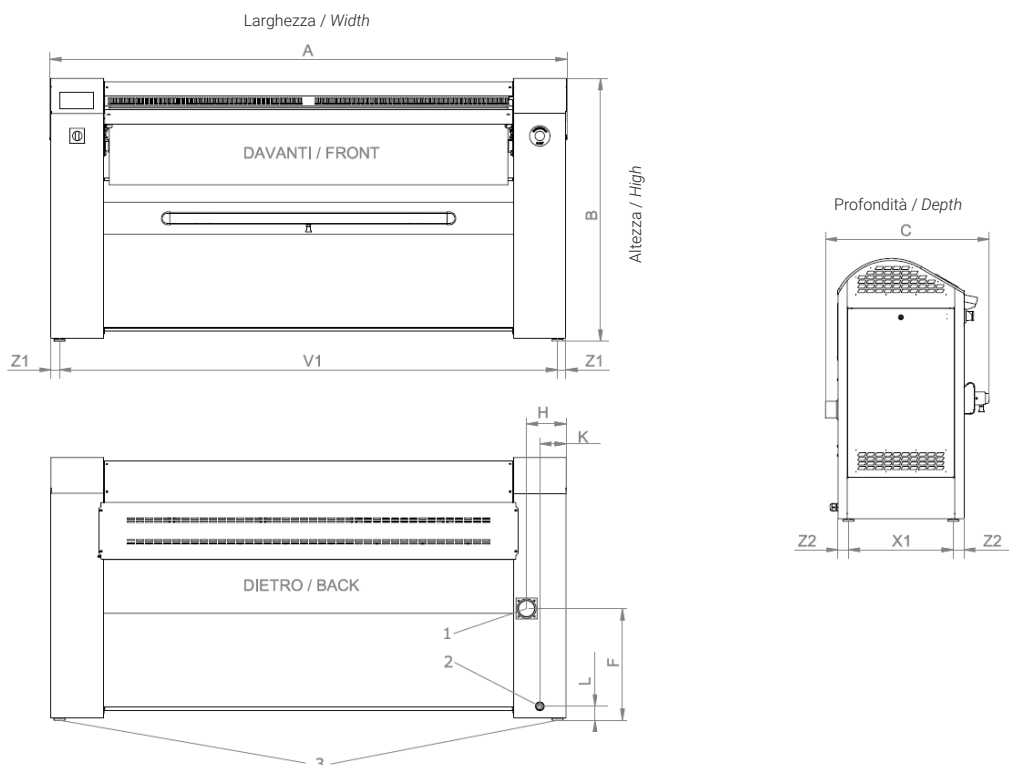

Pos. 1 - Scarico aria umida \ Humid air; Pos. 2 - Alimentazione elettrica / Electrical power supply; Pos. 3 - 4 Piedini (M10) / 4 Feet (M10)

100 mm = 3,93 inch. - fattore di conversione 1 / 25,4 \ factor conversion 1 / 25,4

| [mm]              | A    | B    | C   | F   | H   | K   | L  | V1   | X1  | Z1  | Z2 |
|-------------------|------|------|-----|-----|-----|-----|----|------|-----|-----|----|
| <b>FI 1000/25</b> | 1513 | 1087 | 671 | 462 | 162 | 116 | 62 | 1127 | 460 | 193 | 46 |
| <b>FI 1250/25</b> | 1763 | 1087 | 671 | 462 | 162 | 116 | 62 | 1377 | 460 | 193 | 46 |
| <b>FI 1500/25</b> | 2013 | 1087 | 671 | 462 | 162 | 116 | 62 | 1627 | 460 | 193 | 46 |



imesa.it

Via degli Olmi 22 31040 Cessalto TV Italia - info@imesa.it

**imesa**  
designing your clean



SOLUZIONE PER LA STIRATURA - LINEA FI  
IRONING SOLUTION - FI SERIES

SCHEDA COMMERCIALE  
COMMERCIAL SHEET

**MANGANI A RULLO FI 1500 - 1750 - 2000 Ø 33**  
**FLATWORK IRONERS FI 1500 - 1750 - 2000 Ø 33**



SCANSIONA PER ALTRE INFO  
SCAN FOR MORE INFO

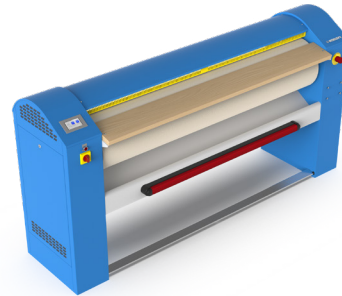
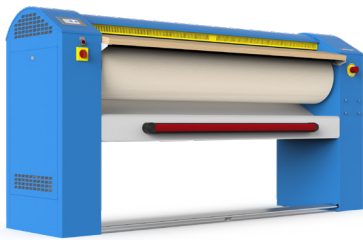
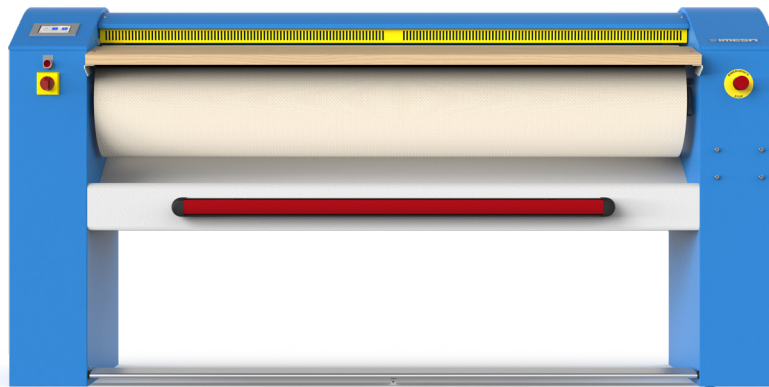

VALORI PRODOTTO / HIGHLIGHTS



IM 10 - Computer Touch screen  
IM10 - Computer Touch Screen



Infiniti programmi di stiro e parametri stiratura modificabili a ciclo avviato  
Infinite ironing solutions and adjustable ironing parameters during the cycle



Variazione automatica della velocità di stiro in funzione della temperatura con sistema Cool Down  
Automatic regulation of ironing speed depending on residual moisture. Cool down system included.



Azionamento lineare per controllo della pressione di stiro  
The linear activation function allows ironing pressure to be controlled and adapted to the type of treated fabric.



Barra di torsione per l'uniformità della pressione della conca su tutta la lunghezza del rullo  
Torsion bar guarantees uniform pressure of the chest throughout the entire length of the roller



Inverter di serie per il controllo elettronico della velocità di stiro e pedaliera per avvio e stop stiratura  
Electronic ironing speed control by inverter and ironing start and stop pedals



Posizione del tavolo di introduzione regolabile  
Adjustable introduction table



Telo di rivestimento in NOMEX di serie, resistente ad alte temperature  
Nomex chest paddle as standard



Barra anti panico sul fronte della macchina  
Anti-panic bar on the front of the machine



Conca di riscaldamento in acciaio cromato  
Chromed steel heating chest



CONTROLLO DELLA PRESSIONE  
-Tecnologia brevettata - TV2008A000116  
PRESSURE CONTROL  
- Patented technology - TV2008A000116

OPTIONAL / OPTIONS

- Rivestimento rullo a molle / Roller with metal mesh



**DATI TECNICI\* / TECHNICAL DATA\***
**FI 1500 Ø33**
**FI 1750 Ø33**
**FI 2000 Ø33**

|   |                                |                              |                                |
|---|--------------------------------|------------------------------|--------------------------------|
| - Lunghezza utile di stiro / Ironing width  | 1500 mm (59,1 inch.)           | 1750 mm (68,9 inch.)         | 2000 mm (78,7 inch.)           |
| - Diametro del rullo Ø / Roller diameter Ø  | 330 mm (1,3 inch.)             | 330 mm (1,3 inch.)           | 330 mm (1,3 inch.)             |
| - Produzione oraria** / Hourly production**   | 40 kg/h (88 lb/h)              | 50 kg/h (110 lb/h)           | 60 kg/h (132 lb/h)             |
| - Evaporazione** / Evaporation**  | 8 lt/h                         | 10 lt/h                      | 12 lt/h                        |
| - Velocità di rotazione / Rotation speed  | 1÷6 mt/min                     | 1÷6 mt/min                   | 1÷6 mt/min                     |
| - Pressione di stiro / Ironing pressure   | 214÷322 kg/m <sup>2</sup>      | 214÷322 kg/m <sup>2</sup>    | 214÷322 kg/m <sup>2</sup>      |
| - Scarico aria umida (pos. 1) Ø / Humid air (pos. 1) Ø  | 73 mm (29 inch.)               | 73 mm (29 inch.)             | 73 mm (29 inch.)               |
| - Portata aria umida / Humid air flowrate   | 200 m <sup>3</sup> /h          | 200 m <sup>3</sup> /h        | 200 m <sup>3</sup> /h          |
| - Intensità sonora area / Air sound intensity   | 55 db (A)                      | 55 db (A)                    | 55 db (A)                      |
| - Perdite al mantello / Heating leak  | 3 %                            | 3 %                          | 3 %                            |
| - Filetto piedini / Feet thread   | M10                            | M10                          | M10                            |
| - Dimensioni macchina : LxPxH / Machine Dimension : WxDxH (100 mm = 3.93 inch.)               | 2013x671x1157 mm               | 2263x671x1157 mm             | 2513x671x1157 mm               |
| - Peso netto / Net weight   | 220 Kg (485 lb)                | 241 Kg (531 lb)              | 268 Kg (591 lb)                |
| - Dimensioni imballo standard: LxPxH / Standard packing dimension WxDxH (100 mm = 3.93 inch.) | 2100x724x1273 mm               | 2350x724x1273 mm             | 2600x724x1273 mm               |
| - Peso lordo / Gross weight   | 240 Kg (529 lb)                | 261 Kg (575 lb)              | 289 Kg (637 lb)                |
| - Volume imballo / Packaging volume   | 1,6 mc (56,5 ft <sup>3</sup> ) | 1,9 mc (67 ft <sup>3</sup> ) | 2,1 mc (74,1 ft <sup>3</sup> ) |
| - Macchine imballate STD per container 20' / STD. packed machines in to 20' container         | 11 pz.                         | 9 pz.                        | 8 pz.                          |
| - Macchine imballate STD per container 40' / STD. packed machines in to 40' container         | 24 pz.                         | 19 pz.                       | 17 pz.                         |

**DATI MACCHINA RISCALDAMENTO ELETTRICO / ELECTRIC HEATING MACHINE DATA**

|   |                |                |                |
|---|----------------|----------------|----------------|
| - Riscaldamento elettrico / Electrical Heating                                      | 7,5 kW         | 10,5 kW        | 13,5 kW        |
| - Potenza totale (pos. 2) / Total Power (pos 2.)                                    | 8,1 kW         | 11,1 kW        | 14,1 kW        |
| - Assorbimento / Absorptions (3 ph 400V-440V (+N) / 3 ph 230V / 1 ph 230V 50/60 Hz) | 13 / 23 / 37 A | 16 / 28 / 51 A | 21 / 37 / 59 A |
| - Consumo orario ** / Hourly consumption**  | 6,6 kWh        | 9,0 kWh        | 11,4 kWh       |

\* I dati sono riferiti a macchine dotate di aspirazione / Data refer to aspiration fan machines.

\*\* 20% di umidità residua e utilizzo del rullo al 100% (ISO 9398) / 20% of residual humidity and use of 100% of roller length (ISO 9398)

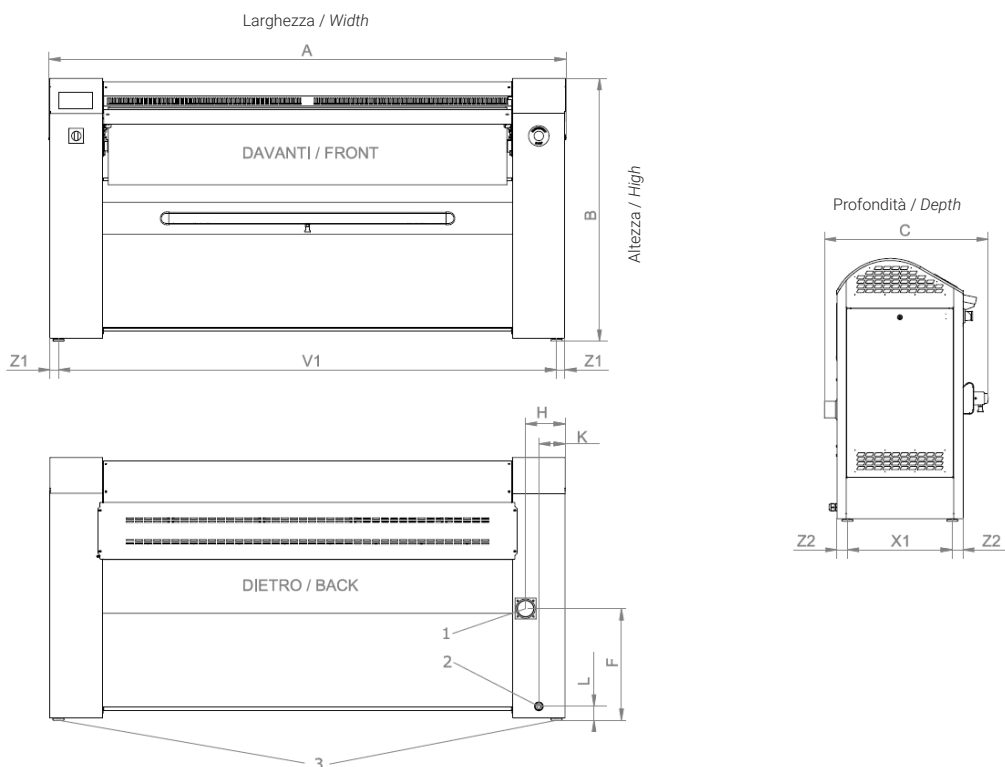

Pos. 1 - Scarico aria umida \ Humid air; Pos. 2 - Alimentazione elettrica / Electrical power supply; Pos. 3 - 4 Piedini (M10) / 4 Feet (M10)

100 mm = 3.93 inch. - fattore di conversione 1 / 25,4 \ factor conversion 1 / 25,4

| [mm]              | A    | B    | C   | F   | H   | K   | L  | V1   | X1  | Z1  | Z2 |
|-------------------|------|------|-----|-----|-----|-----|----|------|-----|-----|----|
| <b>FI 1500/33</b> | 1513 | 1087 | 671 | 479 | 162 | 116 | 79 | 1627 | 460 | 193 | 46 |
| <b>FI 1750/33</b> | 1763 | 1087 | 671 | 479 | 162 | 116 | 79 | 1877 | 460 | 193 | 46 |
| <b>FI 2000/33</b> | 2013 | 1087 | 671 | 479 | 162 | 116 | 79 | 2127 | 460 | 193 | 46 |



imesa.it

Via degli Olmi 22 31040 Cessalto TV Italia - info@imesa.it

**imesa**  
designing your clean